

NORTH SHORE EQUITABLE BUILDING

PITTSBURGH, PA

STEPHAN NORTHROP - STRUCTURAL OPTION



REVISED THESIS PROPOSAL

FACULTY CONSULTANT: DR LINDA HANAGAN

APRIL 3, 2011 (REVISION #2)

TABLE OF CONTENTS

Executive Summary	3
1. Introduction	4
2. Structural Systems	5
• Foundation	5
• General Floor Framing	6
• Turret Framing	7
• Roof Framing	8
• Lateral Resisting System	9
3. Applicable Codes	11
4. Problem Statement	12
5. Proposed Solution	13
6. Breadth Options	14
• Acoustics	14
• Construction Management	14
7. Problem Solution Methods	15
8. Tasks and Tools	16
9. Schedule	18
10. Conclusion	19

EXECUTIVE SUMMARY

This thesis proposal focuses on the North Shore Equitable building, a six story low rise commercial office building located on Pittsburgh's North Shore. The existing structural system of this building consists of composite steel beams and girders to resist gravity loads and a combination of braced frames and moment frames to resist lateral loads. A composite steel system was originally chosen by the designers due to its light weight structure and the ease of design and construction attainable at reasonable costs. A proposed light rail extension line is designed to pass directly below the building, however, and brings different design aspects to the forefront of the project such as noise reduction and vibration damping.

The goal of this project is to redesign the North Shore Equitable Building using an alternative structural system in an attempt to improve noise control as well as maintaining the existing grid layout. From Tech Reports 1 through 3, it was determined that both the existing composite steel frame system and a one way joist and beam system are viable options for the design of the North Shore Equitable building.

The proposed solution for this thesis is to redesign the building using a one way concrete joist and beam system. This alternate structural system has inherent vibration resistance and will potentially decrease vibrations and noise transmission throughout the building. Using a one way joist and beam system will allow for the existing column grid to be maintained as well.

In addition to the structural depth study, two non-structural breadth studies will be conducted as part of this thesis as well. A cost and construction analysis will be necessary to analyze the potential changes in cost and scheduling brought on by the change in building material from steel to concrete. An acoustical study will also be conducted to research the effect a joist and beam system has on noise transmission and vibration as compared the existing composite steel system. In addition to these studies, the lateral resisting system and building foundation may need to be redesigned as well due to the change in structural system.

1. INTRODUCTION

The North Shore Equitable Building is a 6 story, 180,000 square foot low rise commercial office building located on Pittsburgh's North Shore. Completed in 2004, this building is part of the North Shore development project between Heinz Field and PNC Park. Of the building's 180,000 square foot area, 150,000 square feet consists of office space on floors 2 to 5 and the remaining 30,000 square feet is retail space on the ground level. In addition to the 6 above grade levels, one sublevel of parking is also provided, which accommodates 80 vehicles. The North Shore Equitable Building offers its tenants amenities such as an employee fitness center, a test kitchen for product development and the North Shore Riverfront Park which offers access to riverside trails and beautiful views of the Pittsburgh skyline across the Allegheny River.

Among the Equitable building's notable architectural features are what is referred to as a turret, located at the southwest corner of the building and two towers located at the northwest and southeast corners of the building respectively. The majority of the building's façade consists of cast stone masonry units up to the third level and a combination of composite metal paneling and face brick from the third level up to the roof level. Two skylights can be found on the roof as well with the architectural designs including a location for a proposed third skylight which was never built.



Figure 1-1: View of the North Shore Equitable building from Mazerowski Way

2. STRUCTURAL SYSTEMS OVERVIEW

The structural system of the North Shore Equitable Building consists of composite steel beams and girders to resist gravity loads and a combination of braced frames and moment frames to resist lateral loads. These components of the building's structural design, along with all other structural design components, will be described in further detail below.

Foundation

The foundation consists of a 5 ½" slab on grade supported by concrete grade beams and a combination of 18" auger cast piles and steel H-piles. Reinforced concrete retaining walls in the parking garage extend from the top of the grade beams to the first floor framing. These walls are restrained at the top by the first floor framing.

The piles for the Equitable Building pose a unique set of design requirements. The Allegheny Port Authority is currently extending their light rail transit system under the Allegheny River to Pittsburgh's North Shore. This extension consists of two parallel tunnels which are designed to pass directly below the Equitable Building as seen in Figure 2-1. As a result, the foundation is designed as a combination of two types of foundations; driven Steel H-piles (Figure 2-2 on the right) to withstand pressures and settlement resulting from tunneling under the building and 18" auger cast piles (Figure 2-2 on the left) for the remainder of the foundation.

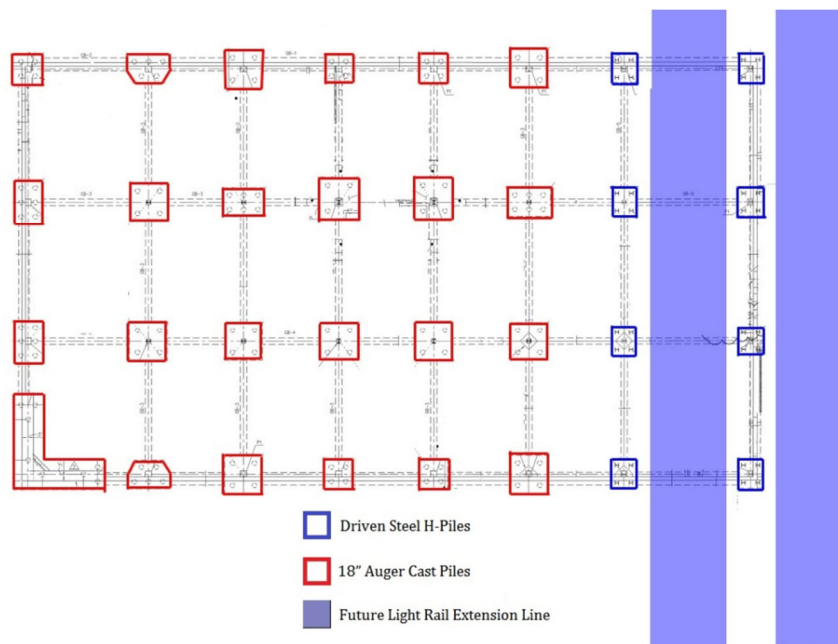

Figure 2-1: Foundation plan with future transit line extension

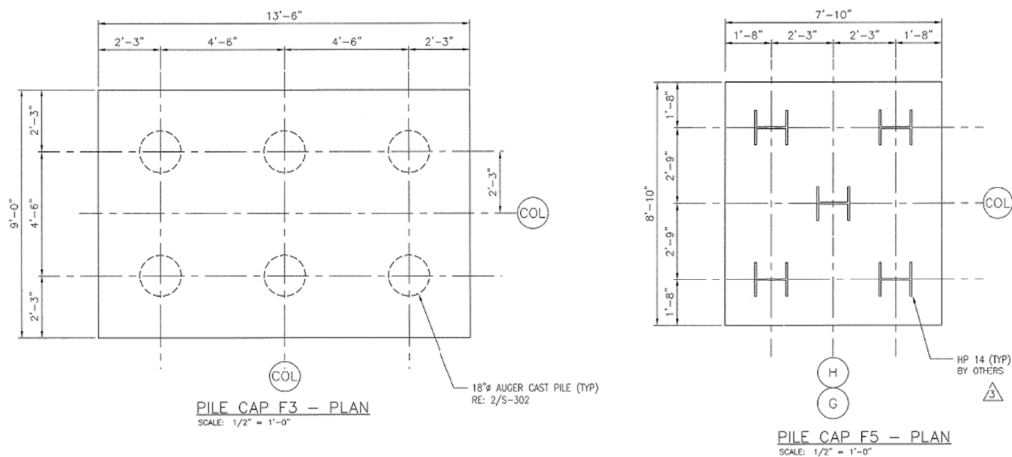

Figure 2-2: Typical 18" auger cast pile cap (left) and typical steel H pile cap (right)

General Floor Framing

Due to the equitable building's rectangular shape, the framing follows a simple grid pattern (128' wide by 228' long). Framing consists of a lightweight concrete slab supported by steel beams girders and columns. The slab has a total depth of 5 1/2" consisting of 3 1/2" lightweight concrete over a 2" 18 gage composite galvanized metal floor deck. The floor is supported by steel beams, typically W18x40's in exterior bays and W21x44's in interior bays, framing into girders ranging in size from W24x62 to W30x116. There are 7 bays on each level (approximately 30' x 42' or 40' x 42' for exterior bays and 30' x 44' or 40' x 44' for interior bays). The beams span 44' in the interior bays and 42' in the exterior bays and are spaced no more than 10' apart. The girders typically span either 30 or 40 feet. Shear studs (4 1/2" length, 3/4" diameter) are used to create composite action between the deck and the steel beams. Figure 2-4 on the following page shows the typical floor plan for the existing structural system.

Columns for the Equitable Building are all W14 wide flange columns ranging in weight from W14x311 on the first level to W14x48 extending up to the roof level. Columns are spliced at two locations along the vertical length of each column line at 4' above the floor level indicated. A typical column splice detail is shown to the right in Figure 2-3.

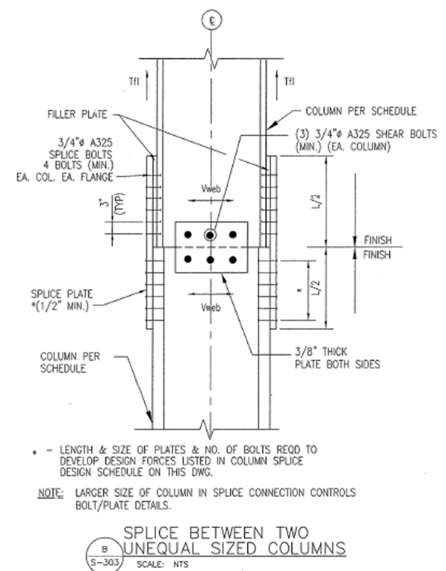

Figure 2-3: Typical column splice detail

Roof Framing Plan

The roof framing system, like the floor framing system, is laid out in a simple rectangular grid. It consists of a 1 1/2" 20 gage type B galvanized roof deck supported by open-web K-series joists (Figure 2-6) which frame into wide flange girders. The roof deck spans longitudinally which is perpendicular to the joist span direction. The K-series joists are generally either 28" or 30" deep and span either 44' (in interior bays) or 42' (in exterior bays). These joists are spaced no further apart than 5' typically.

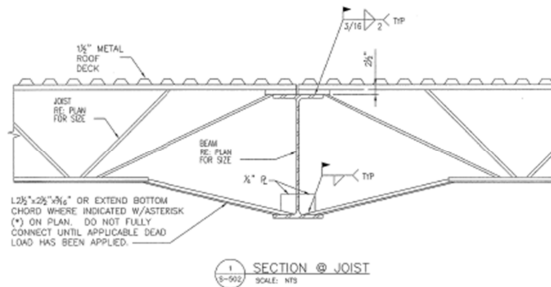

Figure 2-6: Section at joist

The girders in the roof plan vary greatly in both size and span length. Girders carrying the typical roof load vary in size from W18x35's to W30x116's (spanning anywhere from 16' to 44'). The roof girders above the core of the building supporting mechanical equipment are mainly W12x19's and W24's with a few W14's and W18's used as well. 10" and 30" deep KCS-Type open-web K-series joists are also used to help support this equipment.

The framing of the tower roofs consists of C10x20's, W10x22's and L2 1/2 x 2 1/2 x 1/4 horizontal bridging, as seen in Figure 2-7. The framing of the turret roof consists of curved C6x13 members and wide flange members of varying lengths as seen in Figure 2-8.

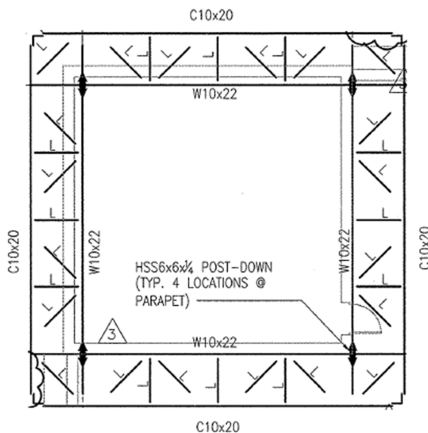

Figure 2-7: Tower roof framing plan

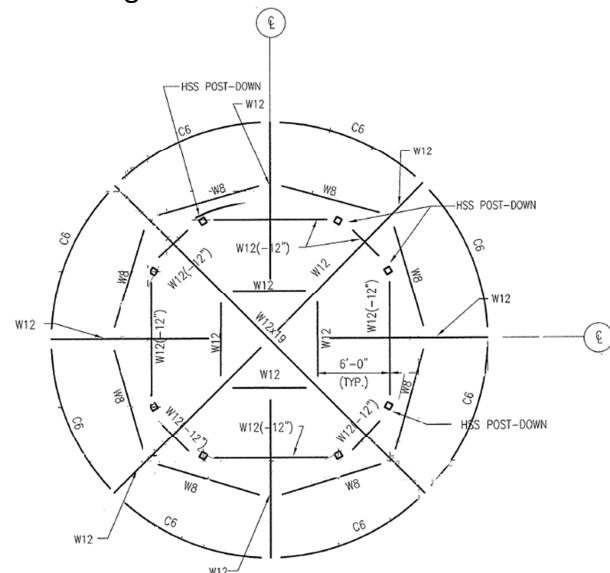

Figure 2-8: Turret roof framing plan

Lateral Resisting System

Lateral stability in the North Shore Equitable Building is achieved through the use of a combination of braced frames and moment frames. Braced frames run in the transverse direction and moment frames run in the longitudinal direction as seen in Figures 2-9 and 2-10 below. The floor and roof decks, which act as horizontal diaphragms, transfer lateral forces to the frames. Elevation views of these frames can be seen in Figures 2-11 and 2-12. The connections in the moment frames are semi rigid connections. Details of a typical braced frame connection and a moment frame connection are shown in Figures 2-13 and 2-14 respectively.

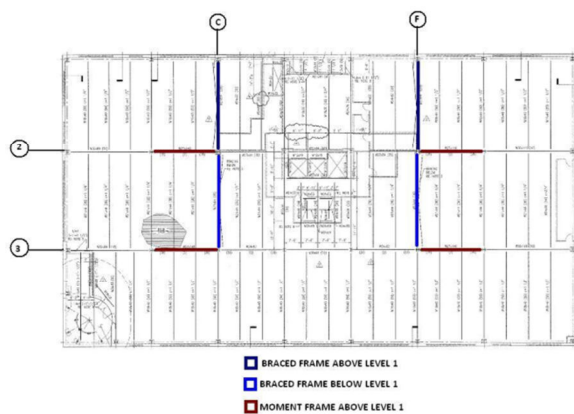

Figure 2-9: Lateral Resisting elements at level 1

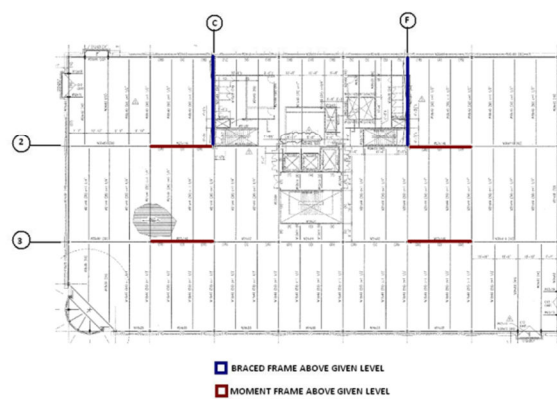

Figure 2-10: Lateral Resisting elements at levels 2-6

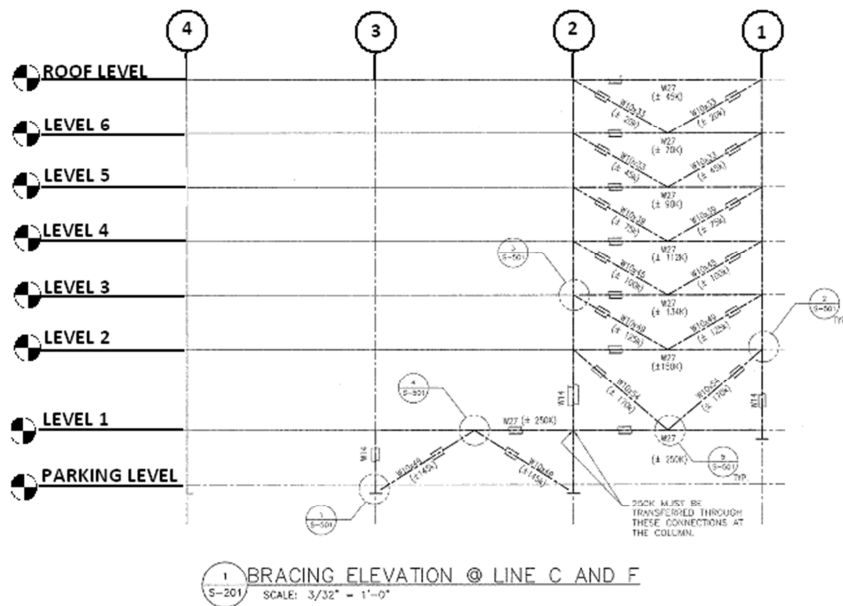
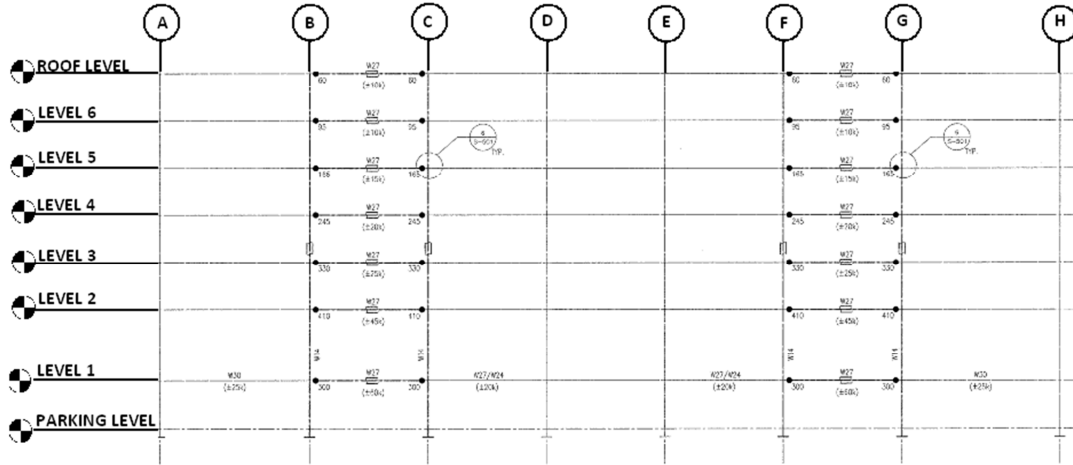
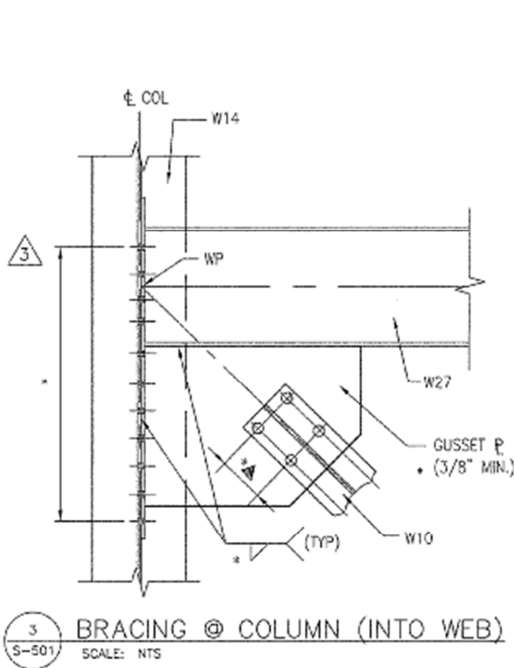

Figure 2-11: Braced frame elevation



2 MOMENT FRAME ELEVATION @ LINE 2 AND 3
 S-201 SCALE: 3/32" = 1'-0"

Figure 2-12: Moment frame



3 BRACING @ COLUMN (INTO WEB)
 S-501 SCALE: NTS

Figure 2-13: Braced frame connection

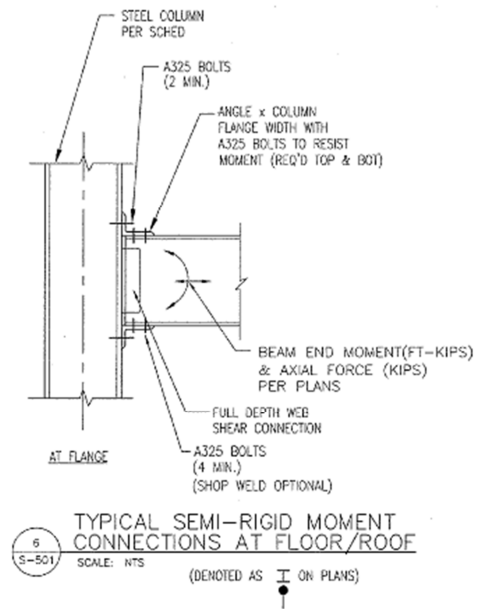

6 TYPICAL SEMI-RIGID MOMENT CONNECTIONS AT FLOOR/ROOF
 S-501 SCALE: NTS (DENOTED AS [symbol] ON PLANS)

Figure 2-14: Moment frame connection

3. APPLICABLE CODES

Since the North Shore Equitable building was designed and built between 2003 and 2004, the codes used by the designers are a couple editions older than the codes used for this report. The codes used by the designers and in this report are given below.

Codes Used In the Original Design

- The BOCA National Building Code, 1999
- City of Pittsburgh Amendments to The Boca National Building Code
- ASCE 7-95, Minimum Design Loads for Buildings
- ACI 301, Specifications for Structural Concrete for Buildings
- ACI 318-95, Building Code Requirements for Reinforced Concrete
- ACI 530, Building Code Requirements for Masonry Structures
- AISC/ASD-89, Manual of Steel Construction, 9th Edition
- AISC/LRFD-2001, Manual of Steel Construction, 3rd Edition
- SJI-41st Edition, Standard Specifications and Load Tables for Steel Joists and Joist Girders

Codes Used In Thesis Proposal

- ASCE 7-05, Minimum Design Loads for Buildings
- AISC Manual of Steel Construction, 13th Edition
- ACI 318-08, Building Code Requirements for Reinforced Concrete

4. PROBLEM STATEMENT

As mentioned in the structural systems overview above, the existing design of the North Shore Equitable Building is a lightweight composite slab supported by steel beams girders and columns to resist gravity loads. Lateral loads are resisted by a combination of braced frames running in the transverse direction and moment frames running in the longitudinal direction.

When this building was originally designed, the engineers were faced with the task of designing the structure to accommodate a future light rail transit line extension that will pass below the building. Because of this, large bay sizes were a requirement so that the foundation would not interfere with the transit line. Larger bay sizes were also emphasized in order to provide more flexibility for future open office space. Incorporating the transit line into this design also makes noise reduction a key design issue.

Project Goal: The goal of this project is to redesign the North Shore Equitable Building with an alternate structural system in an attempt to improve noise control while also attempting to maintain the existing grid layout.

5. PROPOSED SOLUTION

From Tech Reports 1 through 3, it was determined that both the existing composite steel frame system and a one way joist and beam system are viable options for the design of the North Shore Equitable building.

A composite steel system was chosen by the engineers for the original design for several reasons. Steel framing systems are relatively easy to design (compared to concrete systems), quickly and easily erected, and provide a relatively light and open floor plan at a reasonable cost. There are some disadvantages however, such as worse noise control which is one of the focus areas of this thesis.

The proposed solution for this thesis is to redesign the building using a one way concrete joist and beam system. A preliminary analysis of this system in Tech Report 2 yielded a potential floor system thickness of 24.5" consisting of a 4.5" slab and 20" deep joists (as shown in figure 5-1 below). Beams were also estimated with a width of 40" and a depth of 24.5". This alternate structural system has inherent vibration resistance and will potentially decrease noise transmission and vibrations throughout the building. Using a one way joist and beam system will also allow for long spans in the column grid to be maintained. With this new design, the foundation may need to be redesigned to accommodate higher building loads. The lateral system will need to be redesigned as well, and will most likely consist of shear walls strategically placed to minimize torsion. A cost and construction analysis will be necessary since the main material used will change from steel to concrete. In addition to looking at the foundation, lateral system and construction, an acoustical analysis will be necessary to research the effect a joist and beam system has on noise transmission as compared to the existing composite steel system.

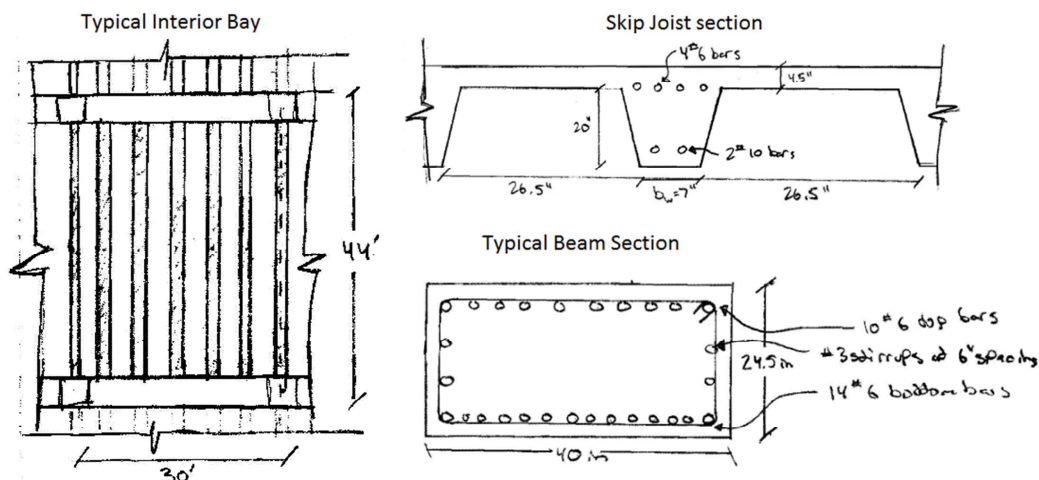

Figure 5 - 1: One way joist and beam system details

6. BREADTH OPTIONS

Acoustics

As previously mentioned, noise reduction is a key design factor that must be taken into account due to the proposed transit line passing below the building. Because of this, an acoustics study will be included in this thesis as a breadth topic. STC and noise reduction values will be investigated for both the existing steel frame system and the proposed joist and beam system. The concrete joist and beam system is expected to have better vibration control and noise reduction values than the composite steel system.

Construction Management

Since the proposed solution for this thesis involves changing the predominate building material from steel to concrete, a new construction schedule and cost estimate will need to be developed. Some factors that will be considered include the need for formwork for the new system and the scheduling implications the difference of lead times between steel and concrete. These new estimates will then be compared to the original schedule and cost information. Construction of the new structural system is expected to be easier than the existing system due to faster lead times and simpler connections. Also, the cost is expected to decrease due to reduced floor heights.

7. PROBLEM SOLUTION METHODS

The first step will be to design the concrete floor system by hand using chapter 8 of ACI 318-08 with the help of the sizes estimated in Tech Report 2 using *Concrete Floor Systems: Guide to Estimating and Economizing* by David Fanella. As mentioned in Tech Report 2, a pan depth of 16" will be investigated for feasibility and compared to the conservative size of 20" used in Tech Report 2. Concrete beams and columns will then be designed and checked with hand calculations. Reinforcing will be sized either by hand or using computer software. If necessary, *Reinforced Concrete: Mechanics and Design* by James K. Wight will be referenced for design examples. SP column and ETABS will also be considered as potential design tools. If these programs are used, simple hand calculations will be performed to check the accuracy of any computer models. The alternate structural system will be design using the existing grid layout if possible. If it is discovered that using the original column grid leads to excessive slab and member dimensions and excessive building weight, a grid layout with smaller spans will be considered.

Once all member sizes and a grid layout have been determined, a 3D model will be created using either SAP or ETABS. Using this model, the loads applied to the building foundation will be determined. Based on the foundation loads resulting from the new concrete structure, the foundation will most likely need to be redesigned. Some research will need to be done at this stage to become more familiar with steel H-piles and auger cast piles, both of which are utilized in the existing design. ACI 318-08 chapter 15 will be referenced at this stage along with *Principles of Geotechnical Engineering* by Braja M. Das. Professors may need to be consulted as well to confirm the accuracy of the design approach.

The next step will be to design the lateral system for the proposed design. Once lateral loads determined in Tech Reports 1 and 3 have been checked for accuracy, shear walls will be designed using the 3D computer model and ACI 318-08 chapter 11. Locations for these walls will be chosen in order to minimize torsional effects.

Once all the elements of the structural system are in place, all 7 ASCE load combinations will be applied to the model, the controlling load case will be found. Finally, the building will be checked to make sure it can support all applied loads, both gravity and lateral, and deflections will be checked to make sure they fall within industry standards. Hand calculations will be performed at this stage to ensure the accuracy of the model.

8. TASKS AND TOOLS

I. Structural Depth – Redesign structure as one way joist and beam system

1. Design concrete floor system by hand
 - i. Design floor slab using ACI 318-08 chapter 8.
 - ii. Design skip joists using ACI 318-08 section 8.13.
 - iii. Size reinforcement for slab and joists using ACI 318-08 chapters 7 & 12.
2. Design concrete beams and columns by hand.
 - i. Design beams and columns.
 - ii. Size reinforcement for beams and columns using ACI 318-08 chapters 7 & 12.
 - iii. Attempt to keep column grid as consistent with the existing design as possible
3. Model one way joist and beam system in SAP or ETABS
4. Design foundation system
 - i. Research steel H pile and auger cast pile design.
 - ii. Determine loads on foundation using ETABS model
 - iii. Resize current foundation system as necessary
5. Design lateral force resisting system
 - i. Determine lateral loads using ASCE 7-05
 - ii. Apply loads to computer model
 - iii. Design shear walls and choose shear wall locations to minimize torque
 - iv. Check deflections
6. Perform spot checks on typical members to check design

II. Breadth #1: Acoustics

1. Review the basics of acoustics engineering using “Architectural Acoustics by Egan”
2. Research current design from a noise reduction standpoint
 - i. Research the noise created by a light rail transit train and the subsequent noise level within the building.
 - ii. Determine STC and NR values for the existing system
3. Research the new one way joist and beam design from a noise reduction standpoint.
 - i. Determine STC and NR values for elements of the one way joist and beam system.
4. Research noise regulations for office buildings
 - i. Check to make sure new design meet all noise regulations
 - ii. Redesign any areas that don’t meet noise regulations
5. Compare new and existing systems with regards to noise reduction and vibration

III. Breadth #2: Construction Management

1. Determine schedule and cost for existing system
 - i. Obtain and review schedule and cost information for existing building
 - ii. Contact construction manager if necessary
 - iii. Create detailed schedule and cost summary for existing structure
2. Investigate impact of new structural design on building cost and schedule
 - i. Obtain cost and labor information for concrete and formwork
 - ii. Obtain lead time information for all new materials
3. Create detailed schedule and cost summary for one way joist and beam system
4. Compare the differences in cost and scheduling for the existing and new designs

IV. Final Presentation

1. Organize and format final report
2. Prepare PowerPoint presentation
3. Review and practice final presentation
4. Make final updates and adjustments to CPEP website

9. SCHEDULE

			Stephan Northrop Structural Option North Shore Equitable Building Dr. Hanagan				
Senior Thesis Final 3/11/2011		January 28, 2011 Milestone #1			February 18, 2011 Milestone #2		March 4, 2011 Milestone #3
Proposed Thesis Semester Schedule January 2011 - April 2011 - Part #1							
Jan 10th - 16th	Jan 17th - 23rd	Jan 24th - 31st	Feb 1st - 6th	Feb 7th - 13th	Feb 14th - 20th	Feb 21st - 28th	Mar 1st - 6th
Design floor system							
Design beams and columns							
	Model one way joist and beam system in SAP or ETABS						
	Research steel H pile and auger cast pile design						
	Determine foundation loads using ETABS model						
			Resize current foundation system				
			design lateral system in ETABS using new lateral loads				
					Check new lateral system		
					Perform spot checks on joist and beam system		
Finalize proposal							
					Research noise reduction for existing design		
					Research noise reduction for new design		
						research noise regulations	
						research vibration in existing design	
						research vibration in new design	
Milestones							
1	Depth: Redesign structure as a one way joist and beam system			Depth Analysis: One way joist&beam system			
2	Breadth: Perform acoustics analysis on new and existing design			Breadth #1: Acoustics			
3	Breadth: Perform construction analysis on ne and existing design			Breadth #2: Construction management			
4	Finalize the final report						

			Stephan Northrop Structural Option North Shore Equitable Building Dr. Hanagan				
		March 25, 2011 Milestone #4					
Proposed Thesis Semester Schedule January 2011 - April 2011 - Part #2							
Mar 7th - 13th	Mar 14th - 20th	Mar 21st - 27th	Mar 28th - Apr 3rd	Apr 4th - 10th	Apr 11th - 17th	Apr 18th - 24th	Apr 25th - May 1st
Spring Break March 7 - 11	redesign any inadequate areas						
		compare new and existing systems					
	Determine schedule & cost for existing system						
	Investigate impact of new materials on constr.						
		Create schedule & cost for new system					
			compare the new and existing system				
			organize and format final report				
			Prepare presentation				
					Faculty Jury Presentations April 11 - 15		
						Final adjustments to CPEP website	
							Senior Banquet April 30th
Milestones							
1	Depth: Redesign structure as a one way joist and beam system			Depth Analysis: One way joist&beam system			
2	Breadth: Perform acoustics analysis on new and existing design			Breadth #1: Acoustics			
3	Breadth: Perform construction analysis on ne and existing design			Breadth #2: Construction management			
4	Finalize the final report						

10. CONCLUSION

In order to better address the design issue of noise reduction brought on by the light rail transit line extension, while attempting to maintain the existing grid layout, the structural system of the North Shore Equitable Building will be redesigned using a one way skip joist and beam system. This will be achieved through the use of design aids, computer modeling programs and hand calculations. Once the new structural system is designed, it will be compared to the existing design in various design categories to determine whether the proposed design did indeed improve the building in the areas of interest. In addition to the structural depth investigation, a construction breadth study and an acoustical breadth study will be conducted as part of this thesis as well. This research will culminate at the end of the semester with a presentation before a faculty jury.